

27-Line SCSI Terminator

FEATURES

- Complies with SCSI, SCSI-2, SCSI-3 and FAST-20 (Ultra) Standards
- 2.5pF Channel Capacitance during Disconnect
- 100µA Supply Current in Disconnect Mode
- 4V To 7V Operation
- 110 Ohm Termination
- Completely Meets SCSI Hot Plugging
- -900mA Sourcing Current for Termination
- +500mA Sinking Current for Active Negation
- Logic Command Disconnects all Termination Lines
- Trimmed Impedance to 5%
- Current Limit and Thermal Shutdown Protection

DESCRIPTION

UCC5620 provides 27 lines of active termination for a SCSI (Small Computer Systems Interface) parallel bus. The SCSI standard recommends active termination at both ends of the cable.

The UCC5620 is ideal for high performance 5V SCSI systems. During disconnect the supply current is typically only 100µA, which makes the IC attractive for lower powered systems.

The UCC5620 is designed with a low channel capacitance of 2.5pF, which eliminates effects on signal integrity from disconnected terminators at interim points on the bus.

The power amplifier output stage allows the UCC5620 to source full termination current and sink active negation current when all termination lines are actively negated.

The UCC5620, as with all Unitrode terminators, is completely hot pluggable and appears as high impedance at the terminating channels with $V_{TRMPWR} = 0V$ or open.

Internal circuit trimming is utilized, first to trim the 110Ω impedance, and then most importantly, to trim the output current as close to the maximum SCSI-3 specification as possible, which maximizes noise margin in fast SCSI operation.

Consult SSOP-36 Packaging Diagram for exact dimensions.

BLOCK DIAGRAM

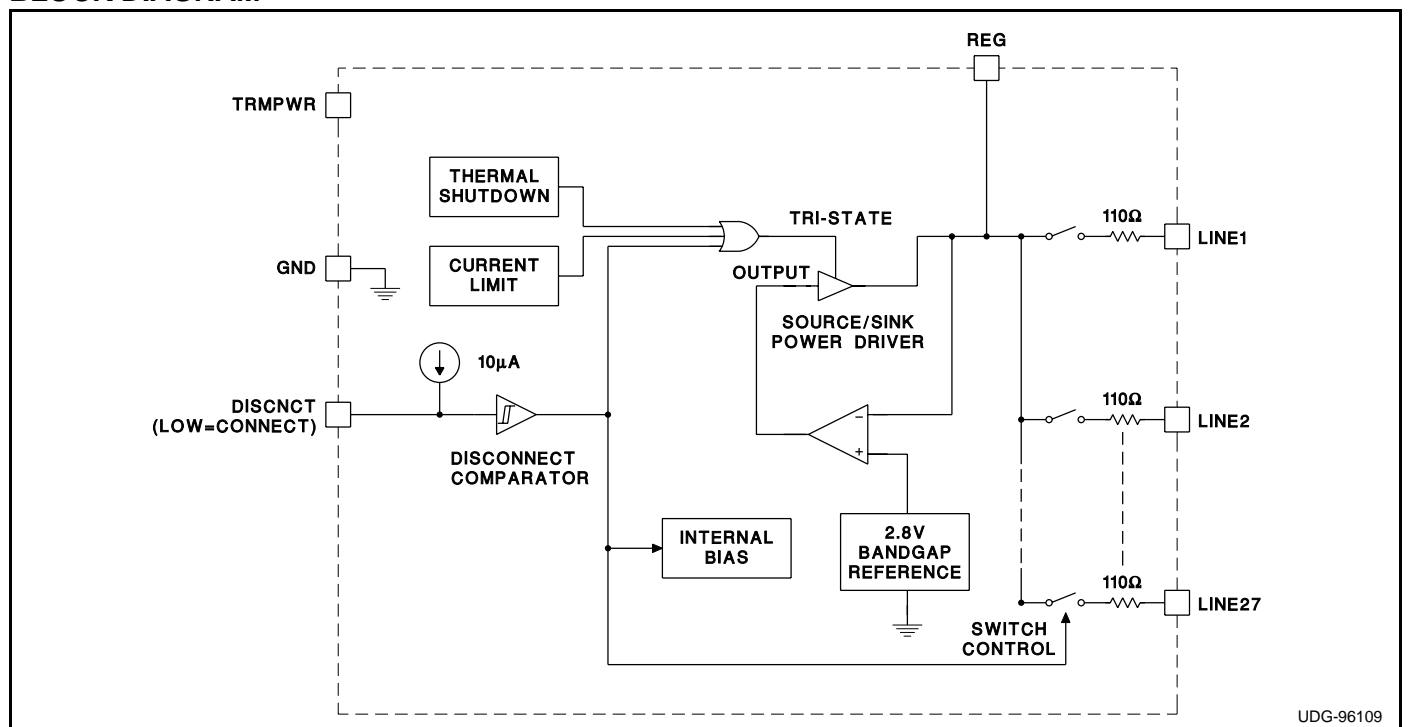

ABSOLUTE MAXIMUM RATINGS

Tempwr Voltage	+7V
Signal Line Voltage	0V to +7V
Regulator Output Current	1.5A
Storage Temperature	-65°C to +150°C
Junction Temperature	-55°C to +150°C
Lead Temperature (Soldering, 10 Sec.)	+300°C

Currents are positive into, negative out of the specified terminal. Consult Packaging Section of Databook for thermal limitations and considerations of packages.

CONNECTION DIAGRAM

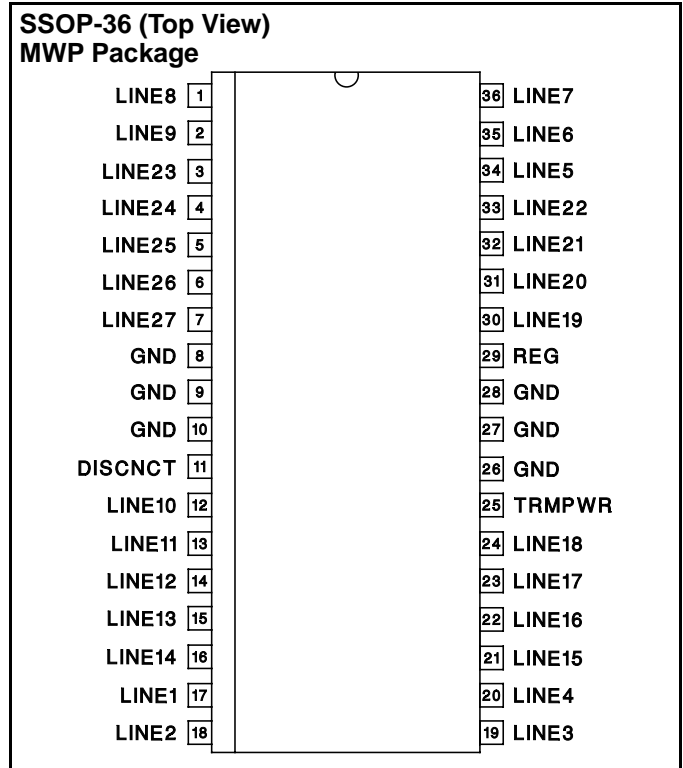

ELECTRICAL CHARACTERISTICS Unless otherwise stated, these specifications apply for TA = 0°C to 70°C, TRMPWR = 4.75V, DISCNCT = 0V, TA = TJ.

PARAMETER	TEST CONDITIONS	MIN	TYP	MAX	UNITS
Supply Current Section					
Tempwr Supply Current	All Termination Lines = Open		1	2	mA
	All Termination Lines = 0.2V		630	650	mA
Power Down Mode	DISCNCT = Tempwr		100	200	µA
Output Section (Termination Lines)					
Termination Impedance	(Note 3)	104.5	110	115.5	Ω
Output High Voltage	(Note 1)	2.6	2.8	3.0	V
Max Output Current	VLINE = 0.2V, TJ = 25°C	-22.1	-23.3	-24	mA
	VLINE = 0.2V	-20.7	-23.3	-24	mA
	VLINE = 0.2V, TRMPWR = 4V, TJ = 25°C (Note 1)	-21	-23	-24	mA
	VLINE = 0.2V, TRMPWR = 4V (Note 1)	-20	-23	-24	mA

ELECTRICAL CHARACTERISTICS (cont.) Unless otherwise stated, these specifications apply for TA = 0°C to 70°C, TRMPWR = 4.75V, DISCNCT = 0V, TA = TJ.

PARAMETER	TEST CONDITIONS	MIN	TYP	MAX	UNITS
Regulator Section					
Regulator Output Voltage		2.6	2.8	3.0	V
Drop Out Voltage	All Termination Lines = 0.2V		0.4	0.8	V
Short Circuit Current	VREG = 0V	-650	-900	-1300	mA
Sinking Current Capability	VREG = 3.5V	300	500	900	mA
Thermal Shutdown			170		°C
Thermal Shutdown Hysteresis			10		°C
Disconnect Section					
Disconnect Threshold		0.8	1.5	2.0	V
Input Current	DISCNCT = 0V		-20	-60	µA

Note 1: Measuring each termination line while other 26 are low (0.2V).

Note 2: Guaranteed by design. Not 100% tested in production.

Note 3: Tested by measuring IOUT with VOUT = 0.2V and VOUT with no load, then calculate:

$$Z = \frac{V_{OUT \text{ N.L.}} - 0.2V}{I_{OUT \text{ at } 0.2V}}$$

PIN DESCRIPTIONS

DISCNCT: Taking this pin high or leaving it open causes all channels to become high impedance, and the chip to go into low-power mode; a low state allows the channels to provide normal termination.

LINE1 - 27: 110Ω termination channels.

REG: Output of the internal 2.7V regulator.

TRMPWR: Power for the IC.

GND: Ground reference for the IC.

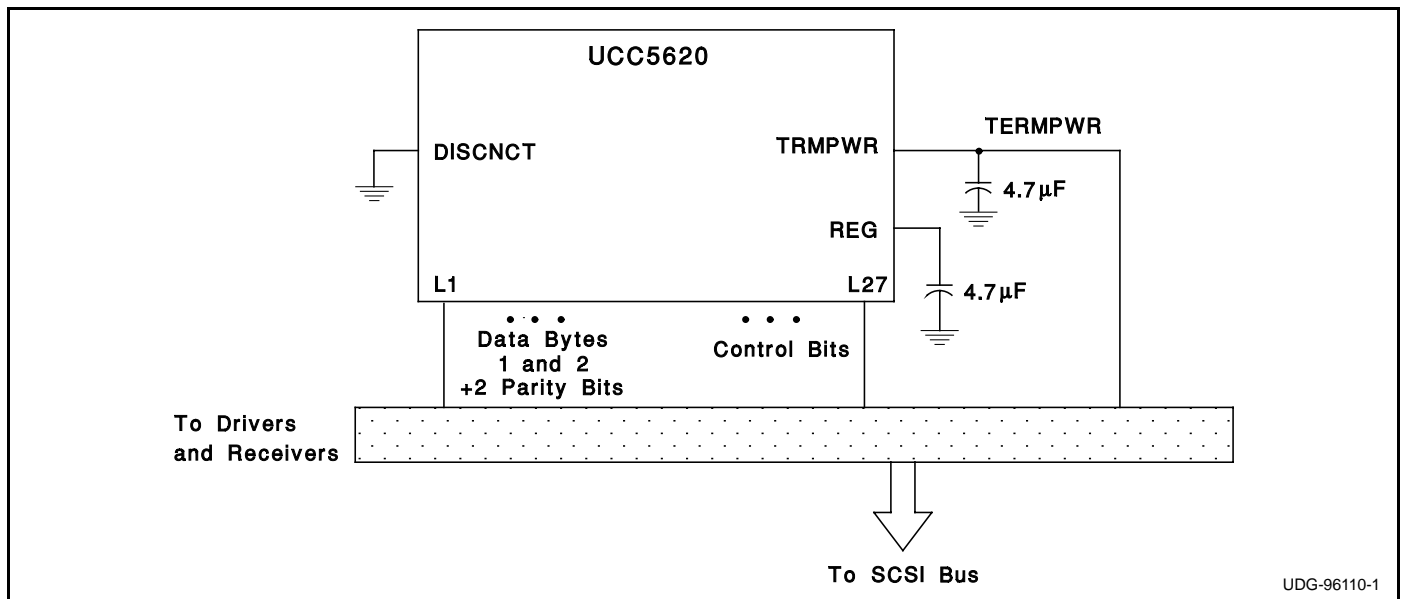
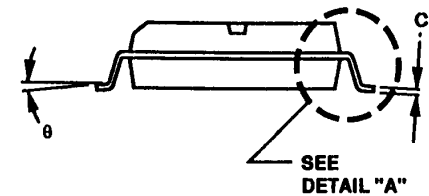
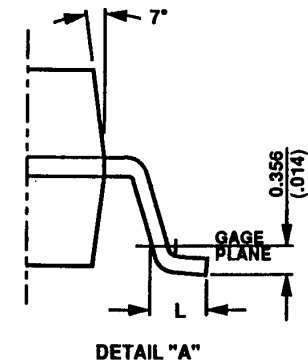
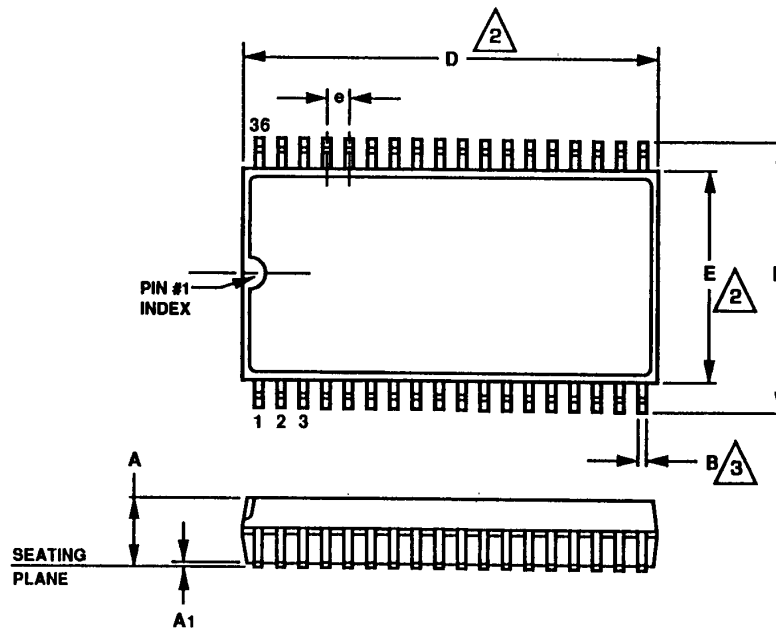

Figure 1. Typical Wide SCSI Bus Configuration Using the UCC5620

VENDOR	

REV. NO.	REVISIONS	DATE	APP'D.
-	INIT PER SCN #18179	01/15/96	

SYMBOL	DIMENSIONS			
	MIN		MAX	
	MM	INCHES	MM	INCHES
A	2.35	.093	2.65	.104
A1	0.10	.004	0.30	.012
B	0.28	.011	0.39	.015
C	0.15	.006	0.32	.0125
D	15.20	.598	15.60	.614
E	7.40	.291	7.60	.299
e	0.80 MM .031 INCHES BSC			
H	10.00	.394	10.65	.419
L	0.40	.016	1.27	.050
θ	0°		8°	



NOTES:

- CONTROLLING DIMENSION: MILLIMETERS. INCHES SHOWN FOR REFERENCE.
- 'D' AND 'E' DO NOT INCLUDE MOLD FLASH OR PROTRUSIONS. MOLD FLASH OR PROTRUSIONS SHALL NOT EXCEED 0.15mm PER SIDE.
- THE BASIC LEAD SPACING IS 0.80mm BETWEEN CENTERLINES. EACH LEAD CENTERLINE SHALL BE LOCATED WITHIN 0.20mm OF ITS EXACT TRUE POSITION AT MAXIMUM MATERIAL CONDITION RELATIVE TO THE CENTER OF THE PACKAGE BODY.
- LEADS SHALL BE COPLANAR WITHIN 0.10mm AT THE SEATING PLANE.

DRAWN	RJV	DATE	1/96
APP'D	<i>RJM</i>	DATE	2/96
TOLERANCES (U.O.S.)			
.XX ± .01			
.XXX ± .005			
FRACTIONS ± 1/64"			
ANGLES ± 1/2°			
SURFACE QUALITY ✓			



UNITRODE

INTEGRATED CIRCUIT CORP.
MERRIBACK, N.J.

TITLE	36 LEAD SSOP PACKAGE OUTLINE DRAWING
DWG NO.	MA 2154
SCALE	SHEET 1 OF 1